

56' Cruising Cat w/AeroRig

This 56' world cruising catamaran was built by a father and son team of Barry and Mark Philbrook. It was launched in 2003 and is now cruising the South Pacific.

The workmanship is superb and it is one of the best owner built KHSD multihulls that I have yet seen.

The client's design mission statement required in particular, shorthanding ease, safety at sea under all conditions, lowest possible drag to windward, livaboard ability year around, and extended open ocean cruising.

They also wanted unlimited visibility forward and to the sides.



SARABI a KHSD 56 CATAMARAN

When I visited them in September of 04, I was impressed how it sat on its lines even though it was packed to the gills with cruising gear, including 300' of anchor chain. The Philbrooks first contacted me after seeing some hulls that I designed for Kevin Millet on his own cruising boat (at the moment in a trans-pacific cruise). See www.hobohobocharters.com.

I do hear that a lot. People see one of Kevin's catamarans and tell me that they want another one like it. A sistership is also now being built in Hawaii.

Why Use an AeroRig

Safety

I recall one night sailing a high performance cat down the Tasman Sea, bound for Hobart. We were near those 100 meter high cliffs, just a few kilometers from the starboard turn that would put us in the Bay of Storms on the way to Hobart. It was about 2 in the morning and the winds were 3 or 4 knots. We were about a kilometer from the cliffs. Suddenly a williwaw bounded down off the cliffs and we had about 35 knots of wind dead aft of us. It only lasted about two minutes and we survived without cartwheeling, but there was nothing we could do to depower. We just had to bear it out. If we had had an AeroRig, we could have instantly weathercocked the rig and depowered.

As probably everybody knows, the AeroRig, or the newer Freewing, is an unstayed rotating mast, with a balesrom boom that rotates the jib around as well as the mainsail.

The biggest advantage is the absolute ability to depower in 'Help me Mr. Wizard' conditions.

Ease of Use

It is also so easy to operate that its almost like driving a car. The only winches are the halyard winch and the balestrom control winch, which is very lightly loaded. To tack you just turn the steering wheel, the rig takes care of the rest automatically.



a NEARLY SIDE VIEW, NOTICE THE HULL FLARE.

Reliability

These masts are entirely carbon fiber, in an epoxy resin matrix. The rig is not only immune to corrosion, but has far better longevity than a metal mast. After a few million flexings, an aluminum structure has about 20% its original strength, while one in carbon fiber still has about 50% of its original strength.

As this design has an unstayed mast, that feature also adds to reliability. The mast staying up does not depend on three or more wires and twice as many swages to keep it up against gravity. This inherent and unmatched reliability really adds to safety in another way. The safety of not worrying about the mast falling down on your head is significant. This safety has been underlined by the recent Waikki beach catamaran incident where the mast fell and killed a passenger.

Vessel Parameters

This cat was to be 56' long by 30' wide. Full load displacement was to be just under 30,000 lbs. Given the usual 7% required "bury" of the base of the AeroRig, that would create

maximum loads of 72,000 lbs and the deck and 58,000 lbs at the heel. I assumed the loads applied equally in all directions. While a polar diagram of the loads might show them to vary with direction, I assumed worst case in all directions. For example, a polar diagram would show no aft load from the mast. When things go ugly at sea, that might not be the case any longer.

Prior Art

Forespar appears to have discontinued the AeroRig, but Freewing out of UK seems to have an even better design and would be suitable to this catamaran design.

I have been doing these AeroRig cats for a while, but I still studied all the prior art that I could find.

One of my 30' catamarans in Hawaii was the first multihull in the Pacific to carry an AeroRig. Kevin built that cat and designed the mast foundations.

In the 1999 I designed a 60' cat in New Zealand, also with an AeroRig. It was built but has only ever operated as a powerboat.

I also did the schematic studies for a 60' Aerorig cat in New Zealand. *Jimmy* was unusual as it had no traditional main connective beam, but instead the house sloped down to the deck in all directions becoming the main beam. Like a sort of pyramid.

It was the first time I had designed one like that, and would have required a FEA study to verify the concept before building. Unfortunately for me, the client had the working drawings done by one of those famous guys. The completed boat did look just like my schematics, which was nice to see.

The most widely published catamaran with AeroRig was the 52' design by John Shuttleworth and I studied that design thoroughly. It resolved the large mast side loads by using a space frame made of carbon fiber tubes.



MAST BASE

One of my usual design goals is to have parts of the boat do several jobs if possible. That is often a good way to save weight, save cost, and is simply elegant design.

This cat, or any cat, has to have a cabin floor strong enough to support dozens of people, and it had to have a cabin top strong enough to support breaking waves. As I saw it, these parts shouldn't need very much more material to support the mast. The failure mode would have to be either the entire house or the entire floor moving sideways. That would not happen easily, but the trick would be to have adequate shear transfer be-

tween the floor and the housetop.

I decided to reject the space frame concept for several reasons. The first was the complexity; the sheer number of parts. A great number of parts will surely not be co-cured, so they would then have to be secondary bonded. I feel that primary structure should not be secondary bonded.

A space frame would indeed be best built in carbon due to the slender nature of the parts. Those slender parts would benefit from the high modulus nature of carbon fiber.

If I instead use the house and house sole to support the mast, that would only load those parts with in-plane loads of shear and/or bearing. Carbon fiber has much less advantage over glass in these load conditions, so glass could have been used instead of carbon at great cost saving.

The space frame I saw on the 52 had significant material along the beam centroid. That is where the compression and tension loads meet in the middle. Structure there does the least possible work to resist global bending and deflection.

Again,
every
bridgedeck
cat needs
a
bridgedeck,
and a
house top.
They are
already
there, lets
use them.

The Solution

Finite
element
studies
that I have
done on
similar high
point loads
have

shown me that these loads dissipate very quickly as you move away from the load origin. This means that not that much extra reinforcement needed away from the load point.

The Aero mast contacts the boat at only the two locations, the cabin top, and cabin sole, with large plastic bearings. These bearings are spherical, allowing the mast to bend without the bearings binding.

The bearings at the house top and floor are reinforced with large tapering glass coves. Basically reinforcing the bearings and spreading that lamination out onto the two flat sur-

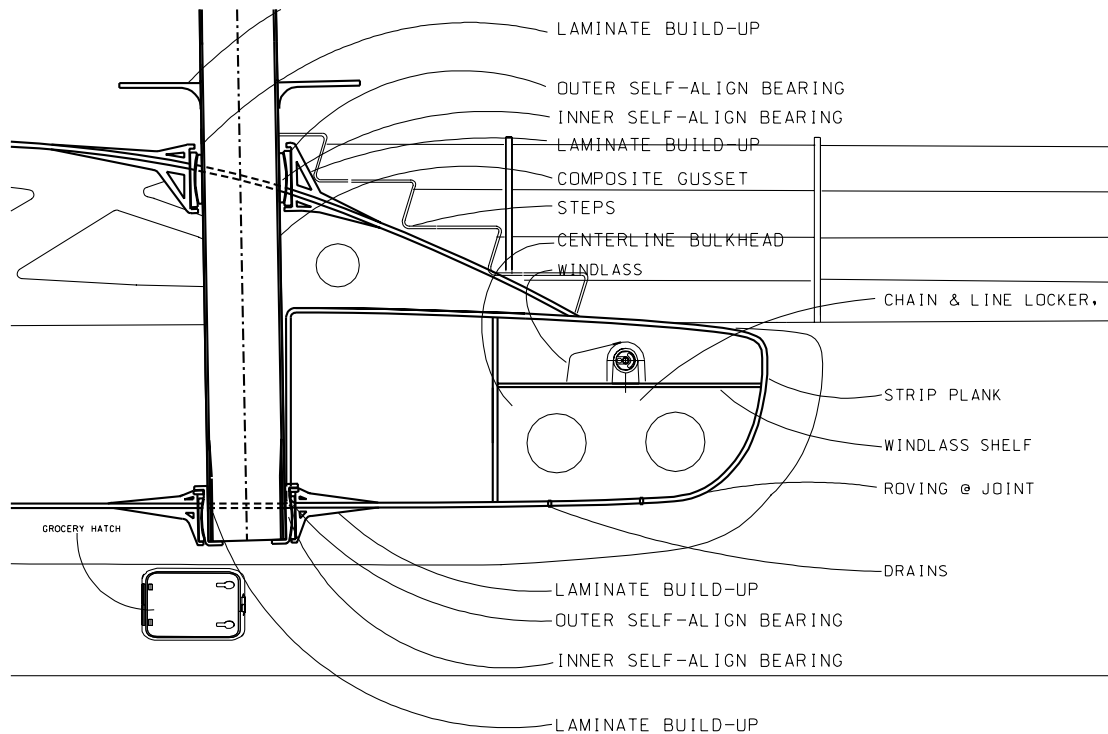

MAST BASE DETAIL

faces is all that is needed. Nearby window cutouts also were given special local reinforcement.

Several subtle methods of enabling shear transfer between the top and bottom structure, without blocking the view were used.

I assumed the glass windows would contribute nothing to resolving the loads, but in fact the clients did purchase 10mm bent, laminated tempered safety glass for the windows. That glass contributes significantly to the shear transfer. Knowing that glass would be used could have reduced the shear transfer detailing.

Construction

Corecell foam and triaxial roving make up most of the structure of this cruising cat. The hulls are 1" (25mm) thick core. The bridgedeck is 2" (50mm) and the house top is also 2"

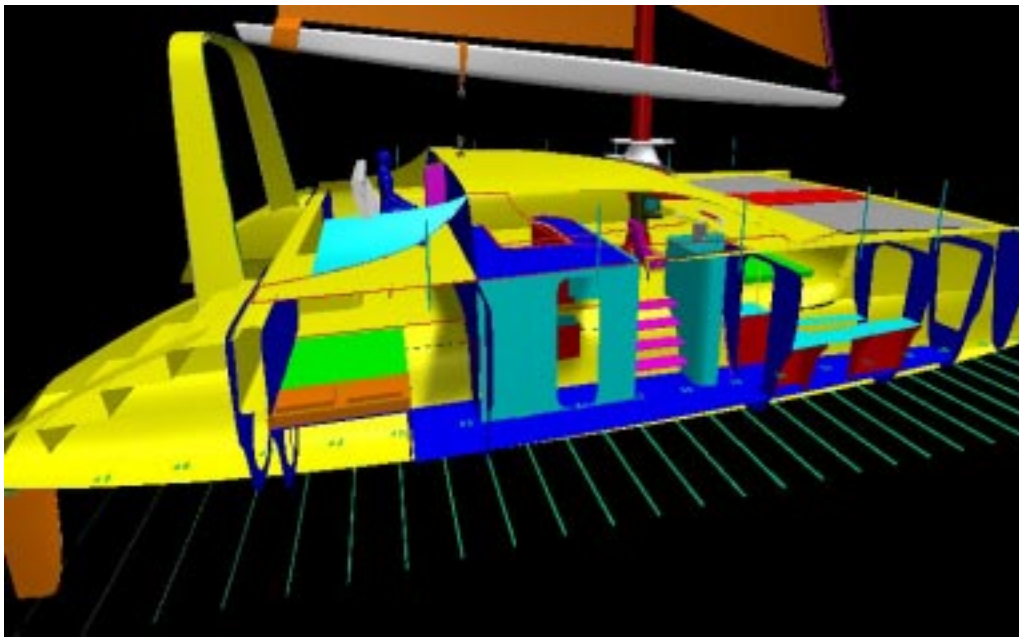

CONSTRUCTION

(50mm) thick. Triaxial roving E glass is used on most of the construction.

The Hulls

The hulls have a relatively skinny waterplane of 11.6/1 but they flare out about a half meter above the waterline to give more interior room. The hull deck beam is 7'-0" (2.13m).

The design displacement is 29,284 lbs (13,283 kg). The prismatic coefficient is 0.615. The power required to push each hull to hull speed is 18 BHP.

Sail Handling

This cat is very easily shorthanded. Once the sails are up, the only control needed is to decide the angle of attack. The helm station is on starboard, up high and protected from

waves.

The main is hoisted by an Anderson 46ST 2 speed electric winch. It also has Anderson 40ST and 46ST 2-spd manual winches.

The mainsail on the Leisure furl boom that was difficult to get working right in the beginning. I recommend slab reefing with one of the easy versions of that.

The jib has a Harken furler.

One feature that Kevin came up with is to add a large fiberglass disk at the base of the



HELM

mast, attached to the mast. A round shelf really. That feature allows the crew to spin around with the mast when standing on it and working the sails, for example reefing and not get knocked down by a sudden change in balance. Sarabi does not have this shelf, but I highly recommend it on future versions of this design. It shows on the earlier construction drawing.

Helm Station

The raised helm station allows for seating for 4 people to enjoy 360 degree visibility, while also providing additional head room in the master stateroom below.

The helm station is above the combination cockpit sunshade and solar panel base.

Inside

This cat, like many others, has four staterooms, in the hulls, with the common space on the bridgedeck.

First stepping into the main salon, one sees the inside helmstation ahead on starboard. It



INSIDE HELM

has an Ekornes "Stressless" nav chair. On port at the front of the salon is the seating area for up to 10.

On port, if you turn that direction, is the entertainment center, complete with keyboard.

Spinning around to starboard is the galley. It has all the features one would find in a home on land. Situated on the starboard side of the main saloon, the galley is well designed with bar and stools so that guests can stay involved when the

owners are cooking.

It features a Force 10 stove & oven with broiler, NuTone Allure WS1 series Range Hood and a NovaKool 12V, R4500 refrigeration. Also find a NovaKool 12V, R3800 and NovaKool Freezer 12V, (10 cu ft) located in the Stbd Hull.

And, find a microwave, coffee maker, double sink, plus literally meters of counter space.

Stepping down into the starboard side hull, all the way aft is the stateroom. It has a queen size berth, seats, vanity, and extensive closets.

Amidships is the head space, with shower.

Immediately forward of the steps down into the hull is the the yachts workshop featuring a Splendide WD 802m washer /dryer and 400 gallon per day watermaker .

The forward stateroom on starboard also has a queen size berth, seats, a dresser, vanity, and a huge walk-in closet.

Sail storage is all the way forward.

The port side hull is arranged in a very similar way to starboard, without the washer/dryer. The plans show the board and trunk only on one side, port, at the owner's request.



LOUNGE

Foils

As noted, this cat was designed with only one dagger board, but two rudders. I have always maintained that boards are not only to provide lift to windward, which one board can do as well as two, but also to protect the props and rudders. The week before I visited this cat, the “naked side” rudder hit a rock and bent the shaft. Those boards are a lot easier to repair than a rudder shaft is. The plans should be revised to show two boards in the next printing.

Engines

Sarabi was designed with an asymmetrical power system . The larger engine is in the port hull for cruising and for safety; the smaller engine is in the starboard hull for maneuvering and generating power. The main engine is a Yanmar 4LHAM-DTP 200hp turbo with Hurth transmission and 2:1 gear ratio.

The starboard motor is an Isuzu 3LD-PW 35 hp with a Hurth transmission of 3:1 gear ratio. At speed, this arrangement caused a 3 degree yaw. On future models, I recommend a more balanced power system.

Engine controls are Kobelt cable controls

The steering system is Wagner Hydraulic NCC2-250-35-A00 w/ Type N steering cylinders Model N50-300, a Model B Helm Pump and it has double acting relief bypass and shutoff valves.

Electrical

It has a 110V/12V Charger/Inverter: Xantrex Prosine PS3.0,3000W Battery monitor:

Xantrex Link 10. There are (8) GRP 6V batteries of 225 Amp hours each

For alternators there is a Leece-Neville 270A on the small engine as main charging. There is also an 80 amp alternator on the big Yanmar. There also is an additional Leece-Neville 200 amp one for back-up



SUN PROTECTION IN THE TROPICS

Solar Panels also generate power with no diesel. It has (6) BP 85W panels with a ProStar-30 regulator.

An Air X Marine-12 wind generator helps out too.

Sailing

The Philbrooks told me they were surprised how well Sarabi sails to weather. Every big

catamaran is basically shoving a large house into the wind. Making that house as aerodynamic as possible, consistent with enclosing the needed space, is an important part of windward performance. Every cat design is a balance between a house and a vehicle. Mine are intended to thrive in the open ocean environment. Sarabi is a vehicle, not just a house.

I often hear the argument that cats need vertical windows to keep the sun out. That's fine, it can get pretty hot in the calm harbor with no tradewinds.

To help mitigate the heat buildup, low E glass can be used, and Sarabi also uses snap-on fabric screens as are popular with powerboats.

Doing away with all the stays has to help windward performance also.

The Philbrooks are now off sailing in the South Pacific with their spaceship. Good for them.

Plans for this very successful catamaran are available at www.multihulldesigns.com or at 206-284-6346. Many more photographs will be online soon.



SARABI UNDERWAY